

DISASSEMBLY & ASSEMBLY BOLTED BONNET PISTON CHECK VALVE
≤ 2" and ≤ 1500 LBS.

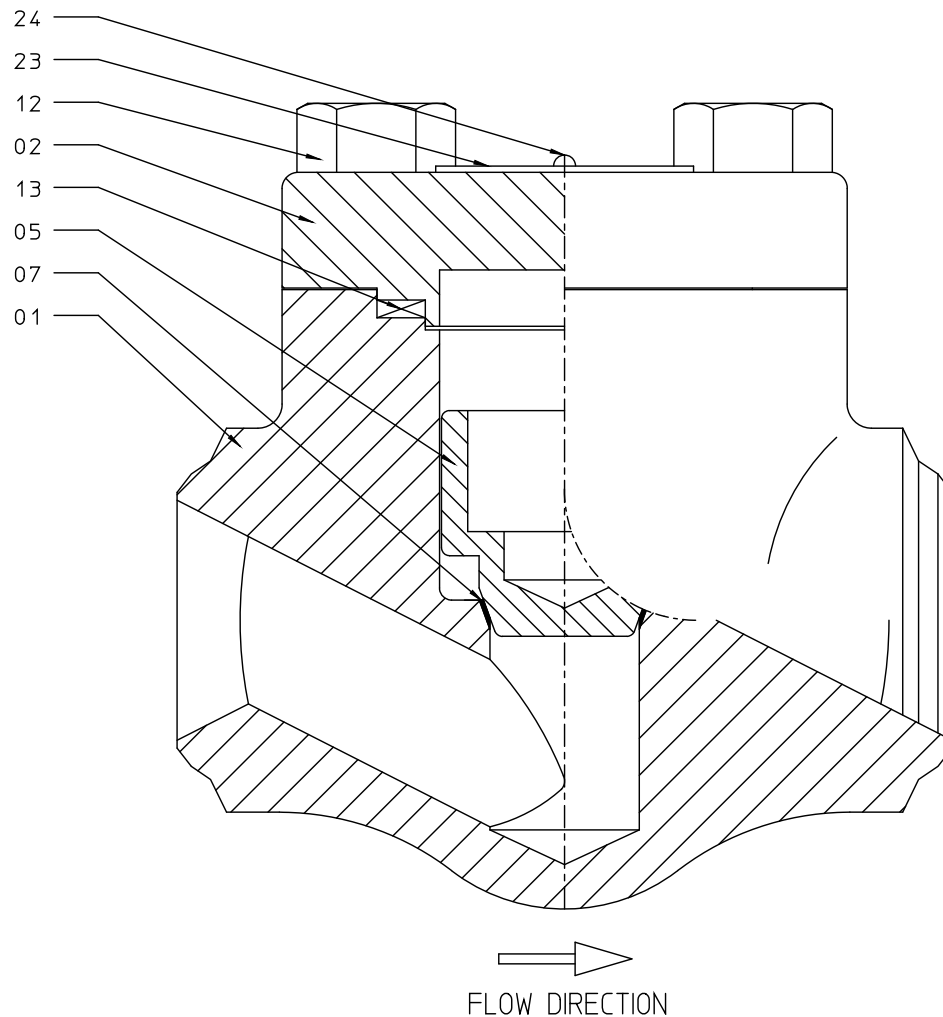

1. Caution, before any attempt is made to disassemble, verify that the valve is sufficiently cooled down, depressurised, isolated from system pressure and secured against accidental pressurisation.
2. Remove the bonnet bolts (12) and lift the bonnet (02) from the valve body (01).
3. Remove the gasket (13) from the valve body (01). Avoid scratching of the mating surface of the valve body (01) and the bonnet (02).
4. Remove the disc (05) from the valve body (01).

INSPECTION PRIOR TO RE-ASSEMBLY

1. Thoroughly clean all parts with solvent and a clean cloth.
2. Examine the following parts for signs of damage, i.e. pitting, erosion or scratches:

- A. SEAT (07) - Sealing surface
- B. DISC (05) - Sealing surface



3. Lubricate all threaded parts with high temperature grease, i.e. Molykote HSC.
4. Insert the disc (05) inside the valve body (01) and install the optional disc spring.
5. Place a new gasket (13) on top of the valve body (01) and install the completed bonnet assembly (02) on top of the valve body (01).
6. Install the bonnet bolting (12) and tighten them according to the torque values given in the IOM.
7. Pressurise the system and check the gasket (13) for signs of leakage.
8. In case leakage is observed, tighten the bonnet bolting (12) carefully until the leaking stops.
9. The valve is now ready for use.