

DISASSEMBLY & ASSEMBLY PARALLEL SLIDE GATE VALVE
 ≤ 2" AND ≥ 1500 LBS.

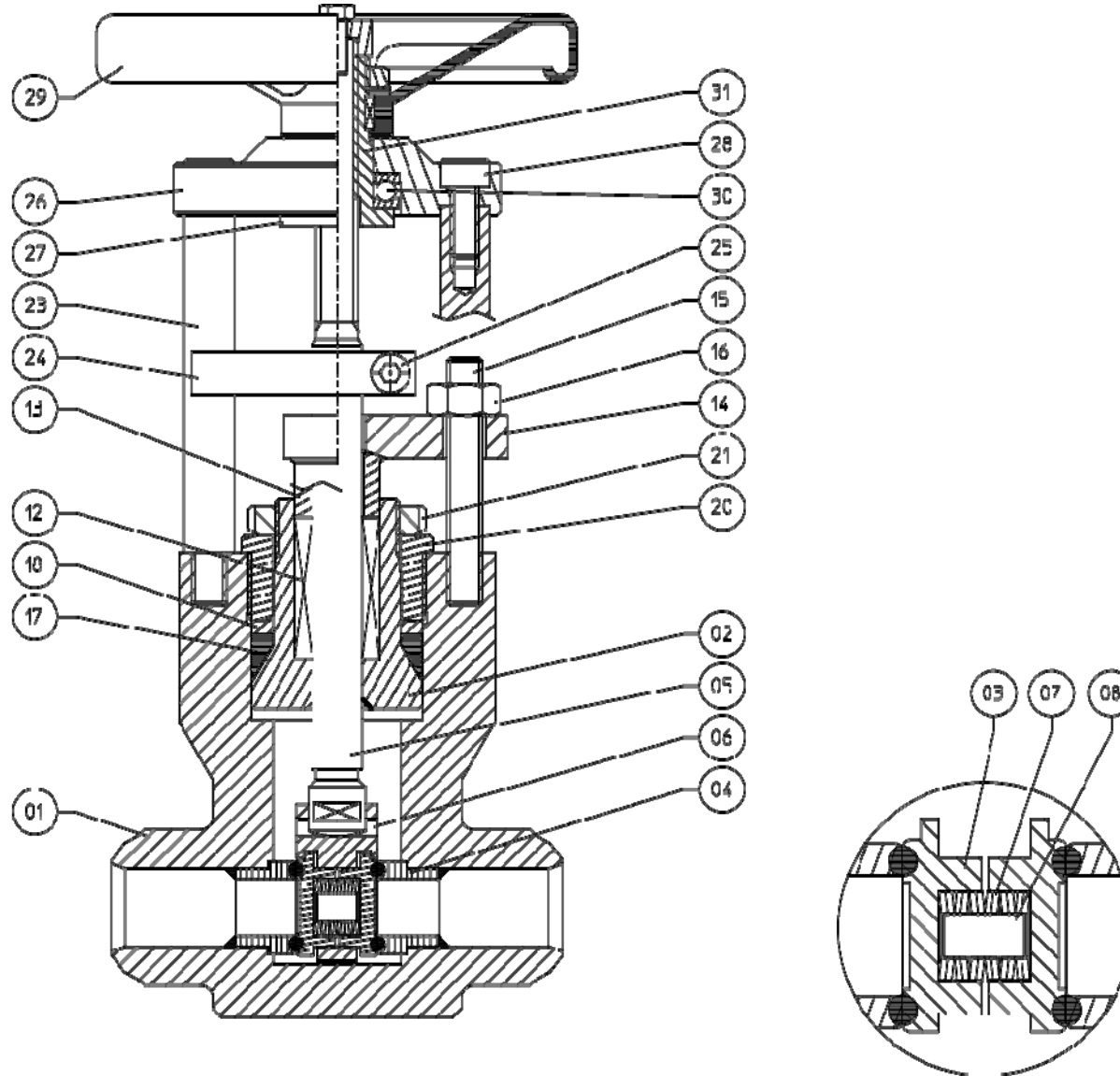

DISASSEMBLY & ASSEMBLY PARALLEL SLIDE GATE VALVE

≤ 2" AND ≥ 1500 LBS.

1. Caution, before any attempt is made to disassemble, verify that the valve is sufficiently cooled down, depressurised, isolated from system pressure and secured against accidental pressurisation.
2. For manual operated valves remove hand wheel nut, hand wheel (29) and parallel key.
For valves fitted with a Gearbox or Electric Actuator, remove the Actuator, by unscrewing the bolts from the lower side of the yoke flange (26).
3. Unscrew the bolts (28) from the yoke flange (26).
4. For manual operated valves screw the yoke sleeve (27) together with the needle bearings (30) from the stem (05).
5. Loosen the bolts (25) from the guiding plate (24) and remove it. Unscrew the yoke bars (23) out of the valve body (01). Unscrew gland bolting/nuts (15 & 16) and remove them. Remove the gland (14) and packing follower (13).
6. Unscrew the nut (21) from the bonnet (02) and unscrew the lock nut (20) from the body (01), while securing the stem (05) in place in order to prevent it from damaging.
7. After the lock nut (20) has been removed, lower the stem (05) and bonnet (02) down into the body (01). Now remove the spacer ring (18) and gasket (17), together with the bonnet (02) and stem (05), by pulling the stem (05) out of the valve body (01).
8. Dis-assemble the "disc assembly" by removing the pin from the disc holder (06). Afterwards you can rotate the first disc-part (03) 90°, so the lip will clear the disc holder (06).

INSPECTION PRIOR TO RE-ASSEMBLY

1. Thoroughly clean all parts with solvent and a clean cloth.
2. Examine the following parts for signs of damage, i.e. pitting, erosion or scratches:
 - A. SEAT (04) - Sealing surface
 - B. STEM (05) - Packing area
 - C. DISC(S) (03) - Sealing surface
 - D. BONNET (02) – Sealing surface



**IN CASE SEVERE DAMAGE IS OBSERVED,
USE REPLACEMENT PARTS INSTEAD!**

3. Lubricate all threaded parts with high temperature grease, i.e. molykote HCS.
4. Install the first disc (03) into the disc holder (06) and rotate the disc 90° in order to secure it, slide the conical springs (07) over the guide pin (08) and place the pin into the corresponding socket located in the first disc (03). Afterwards place the second disc (03) and rotate it 90° as well, now install the pin to finalise the complete disc assembly.
5. Slide the complete disc assembly (06) onto the stem (05).
6. Place the bonnet (02) over the stem (05). Install a **NEW** gasket (17) into the valve body (01), with the spacer ring (18) on top of it.
7. Screw the lock nut (20) into the valve body (01). Pull the stem (05) towards the top of the valve and screw the nut (21) loose onto the bonnet (02). Screw the bolts (22) into the lock nut (21) and tighten them.
8. Place the **NEW** packing (12) over the stem (05) into the bonnet (02). Place the packing follower (13) over the stem (05). Place the gland (14) over the stem (05) and install the gland bolting (15). Evenly tighten the nuts (16) preventing contact between the stem (05) & packing follower (13).
9. Screw the yoke bars (23) into the valve body (01) as indicated. Place the guiding plate (24) on the designated area located at the stem (05) . Secure the guiding plate (24) with the bolting (25).
10. For manual operated valves screw the yoke sleeve (27) together with the needle bearing(s) (30) on the stem (05).
11. Place the yoke flange (26) on top of the yoke bars (23) and secure them with the hexagon socket bolts (28).
12. For manual operated valves turn the yoke sleeve (27) against the yoke flange (26), place the parallel key and handwheel (29) and secure it with the handwheel nut.
13. Pressurise the system and check the packing (12) and bonnet (02) for signs leakage.



Important:

After starting up the system, once the valve has reached its working temperature and pressure, it is recommended to tighten the bolts (22) into the retaining ring (21) to force the bonnet into the gasket (17) for optimum sealing.

14. In case leakage is observed through the packing (12), tighten the nuts (16) of the gland bolts (15) carefully until the leaking stops. In case leakage through the bonnet (02) is observed, tighten the bolts (22) located in the lock nut (21).
15. The valve is now ready for use.