

**DISASSEMBLY & ASSEMBLY SMALL BORE BOLTED BONNET GATE VALVE**  
≤ 2" and ≤ 1500 LBS.

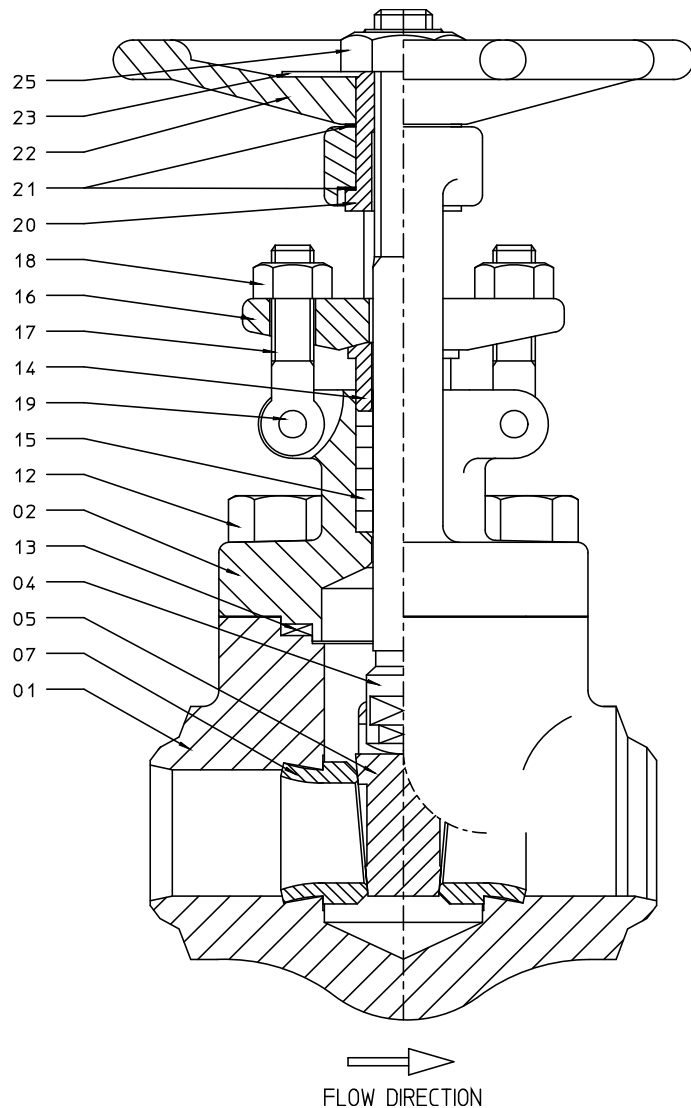

1. Caution, before any attempt is made to disassemble, verify that the valve is sufficiently cooled down, depressurised, isolated from system pressure and secured against accidental pressurisation.
2. Unscrew the handwheel nut (25) and remove the nameplate (23) together with the hand wheel (22) and sleeve ring (21).
3. Remove the bonnet bolts (12) and lift the bonnet assembly (02) from the valve body (01).
4. Slide the wedge (05) from the t-lock end of the stem (04).
5. Remove the gasket (13) from the valve body (01). Avoid scratching of the mating surface of the valve body (01) and the bonnet (02).
6. Loosen the gland bolts (17) by unscrewing the gland nuts (18).
7. Carefully pull the stem (04) out through the bottom of the bonnet (02). Afterwards the yoke sleeve (20) can be removed together with the gland flange (16) and the gland (14).
8. Pull out the remaining packing (15). Do not damage the inside of the stuffing box.

**INSPECTION PRIOR TO RE-ASSEMBLY**

1. Thoroughly clean all parts with solvent and a clean cloth.
2. Examine the following parts for signs of damage, i.e. pitting, erosion or scratches:

- A. SEAT (07) - Sealing surface
- B. STEM (04) - Packing area
- C. WEDGE (05) - Sealing surface
- D. BACKSEAT (02) - Sealing surface



3. Lubricate all threaded parts with high temperature grease, i.e. Molykote HSC.
4. Install the stem (04) through bottom of the bonnet (02) and place a new packing (15) followed by the gland (14), gland flange (16), yoke sleeve (20) and sleeve ring (21) on top of the stem (04).
5. Slide the wedge (05) on the t-lock provided on the stem (04).
6. Place a new gasket (13) on top of the valve body (01) and install the completed bonnet assembly (02) on top of the valve body (01).
7. Install the bonnet bolting (12) and tighten them according to the torque values given in the IOM.
8. Install the gland nuts (18) to the gland bolting (17). Make sure to evenly tighten the nuts (17) to ensure proper alignment of the gland flange (16).
9. Place the sleeve ring (21) on top of the yoke sleeve (20), followed by the handwheel (22), name plate (23) and handwheel nut (25).
10. Pressurise the system and check the packing (15) and gasket (13) for signs of leakage.
11. In case leakage is observed, tighten the gland nuts (18) and/or bonnet bolting (12) carefully until the leaking stops.
12. The valve is now ready for use.